

General Description

UNIT IDENTIFICATION

AIR COOLED CONDENSING UNIT	
CUS	Condensing Unit with Propeller Fan and Scroll Compressor
15-60	Model Size
D	Double Circuit
e.g.	Model CUS 20D

INTRODUCTION

This range of air cooled condensing units covers the range 40 kW to 161 kW in seven model sizes and has been custom designed to maximise performance whilst minimising footprint, profile and noise.

The range is ideal for application on any split system where the benefits of a range of units employing two independent refrigeration circuits can be fully realised.

Airedale condensing units are run, wired, function tested and leave the factory with a holding charge of ozone friendly nitrogen.

These units are purpose designed for outdoor applications and are fully weatherproofed for adverse climatic conditions.

CONSTRUCTION

CUS 15-30D

The base utilises a lock bolted channel sub frame, the upper section being of a pentapost type construction. A totally enclosed weatherproof compressor compartment features full access to all refrigeration components. All items are fabricated from galvanised steel and coated with an epoxy baked powder paint for a durable weatherproof finish.

CUS 40-60D

The cabinet is fabricated from galvanised steel coated with an epoxy baked powder paint, giving a durable weatherproof finish. A fully weatherproofed electrical panel is situated at one end of the unit.

Standard unit paint colour is Charcoal Grey (RAL 7022).

CONDENSER

Large surface area condenser coil(s) manufactured from refrigeration quality copper tubes, with mechanically bonded aluminium fins.

FAN

A 610mm diameter axial flow fan assembly with low noise paddle type blades. The unique external rotor motor design allows the use of a low power output single phase speed controllable motor to power the fan. The motor has inbuilt thermal overload protection, and the assembly is supplied complete with a finger guard for protection.

COMPRESSOR**CUS 15-30D**

All units utilise hermetic scroll compressors fitted with crankcase (oil sump) heater to guard against refrigerant migration during the off cycle and to eliminate oil foaming on start up. Features include internal motor protection and internal vibration eliminators.

CUS 40-60D

All units utilise hermetic tandemsroll compressors fitted with crankcase (oil sump) heater to guard against refrigerant migration during the off cycle and to eliminate oil foaming on start up. Features include internal motor protection and internal vibration eliminators.

REFRIGERATION

Each circuit is fitted with a liquid line shut off valve, complete with integral schraeder connections for ease of maintenance and installation, The suction line is capped and sealed for customer connection. A large capacity filter drier is supplied loose for on site installation. A factory set dual HP/LP switch is fitted to each circuit and features manual reset on high pressure and auto reset on low pressure.

CONTROLS

All units are configured to operate without pump down control.

ELECTRICAL

The panel is sub divided into mains and control sections thereby ensuring voltage integrity between mains (400/230V) and controls (24V). The controls section can be accessed during normal operation of the unit thereby eliminating the possibility of coming into contact with any mains voltage. The panel houses all the necessary sub circuit protection, starters and timers to ensure continuous and efficient operation of the unit. All units are wired to the latest European codes and standards.

OPTIONS**Head Pressure Control**

Head pressure is maintained by a factory fitted, pressure actuated head pressure controller which varies the speed of the fan(s) to provide optimum control under varying ambient conditions.

Alternative Refrigerant

The units can be supplied with Ester oil compressors for use with R407C.

Mains Isolator**CUS 15-30D**

A weatherproof mains isolator can be fitted to ensure mains isolation of the electrical panel during adjustment and maintenance.

CUS 40-60D

A weatherproof door interlocking mains isolator can be fitted to prevent access to the mains section when the electrical power is switched on.

LP Start Kit

If unit operation in an ambient below -5°C is envisaged, a low pressure start kit can be factory fitted which prevents low pressure nuisance tripping on start up.

Phenolic Condenser Coils

In atmospheres where high corrosion is anticipated phenolic coated aluminium finned coils can be supplied.

Capacity Data

	Evaporating Temperature °C	Ambient									
		25°C		30°C		35°C		40°C		45°C	
		Output kW	Input kW	Output kW	Input kW	Output kW	Input kW	Output kW	Input kW	Output kW	Input kW
CUS15D	-5	33.13	9.74	31.47	11.20	29.89	12.67	28.25	12.67	26.54	15.56
	0	38.96	10.30	37.19	11.74	35.45	13.19	33.71	13.19	31.94	16.01
	5	45.27	10.95	43.51	12.36	41.78	13.79	39.93	13.79	37.57	16.48
	10	53.87	11.86	51.50	13.22	49.09	14.57	46.77	14.57	44.58	17.17
CUS 20D	-5	42.84	12.58	40.35	14.58	37.90	16.58	35.46	18.59	32.76	20.74
	0	50.55	13.33	48.05	15.28	45.60	17.24	43.10	18.87	40.25	21.42
	5	62.54	14.21	56.36	15.82	50.16	17.44	44.03	19.06	48.74	22.19
	10	69.48	14.94	66.94	16.78	64.36	18.63	61.43	20.64	58.19	22.67
CUS 25D	-5	56.30	17.02	53.41	19.23	50.55	21.46	47.67	23.67	44.54	26.02
	0	66.78	18.20	63.61	20.30	60.36	22.40	57.14	24.51	53.45	26.87
	5	78.23	19.31	74.67	21.39	71.13	23.49	67.45	25.65	63.30	28.07
	10	90.92	20.73	87.08	22.03	83.17	23.34	78.81	26.27	73.96	29.08
CUS 30D	-5	64.13	21.03	60.95	23.57	57.80	26.11	54.55	28.64	51.10	31.65
	0	75.92	22.42	72.33	24.92	68.71	27.42	65.04	30.10	61.01	33.21
	5	89.10	23.81	84.88	26.31	80.73	28.81	76.41	31.68	71.80	34.81
	10	103.02	25.32	98.38	27.72	93.74	30.26	88.70	33.21	83.32	36.60
CUS 40D	-5	81.68	22.87	77.28	27.32	72.87	31.76	67.49	36.45	62.11	41.14
	0	96.69	26.69	91.11	30.23	85.53	33.76	79.27	37.89	73.00	42.01
	5	114.25	27.38	109.11	31.47	103.96	35.56	97.95	39.89	91.93	44.21
	10	132.65	30.33	127.50	33.90	122.34	37.47	115.94	41.75	109.53	46.02
CUS 50D	-5	103.65	30.79	97.85	35.52	92.05	40.25	84.50	44.89	76.95	49.53
	0	121.95	34.03	115.47	38.27	108.98	42.51	100.64	47.57	92.30	52.63
	5	143.50	36.65	137.45	40.79	131.40	44.93	123.54	49.88	115.68	54.82
	10	168.16	39.10	160.14	43.25	152.12	47.39	144.01	52.42	135.89	57.44
CUS 60D	-5	129.15	38.61	122.12	43.25	115.08	47.89	108.68	53.01	102.28	58.13
	0	150.40	40.87	143.65	45.55	136.89	50.22	129.59	55.55	122.28	60.88
	5	177.65	43.49	169.53	48.14	161.41	52.79	152.24	58.26	143.06	63.72
	10	206.00	46.25	196.43	50.75	186.86	55.25	177.07	61.42	167.28	67.59

Notes:

- 1 Output kW refers to compressor duty.
- 2 Input kW refers to the compressor input power only.

Operating Data

OPERATING LIMITS

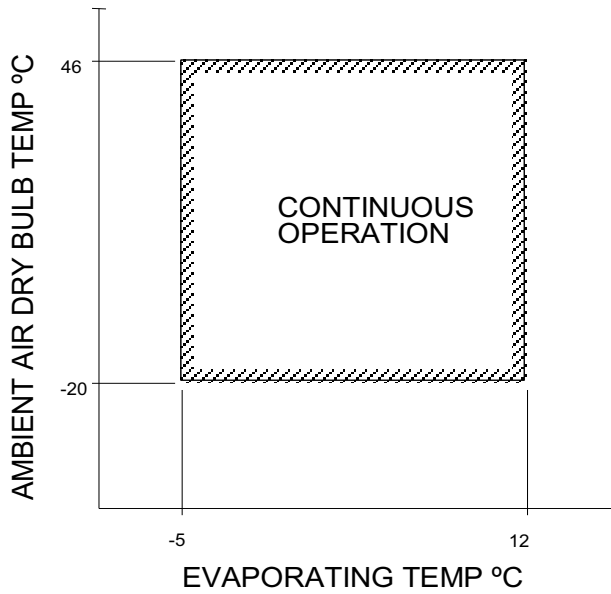

The accompanying operating limits are for general guidance only. It may be possible for certain units to operate outside the confines of the graph. Please contact Airedale if further clarification is required.

Dimensions: CUS 15D - 30D

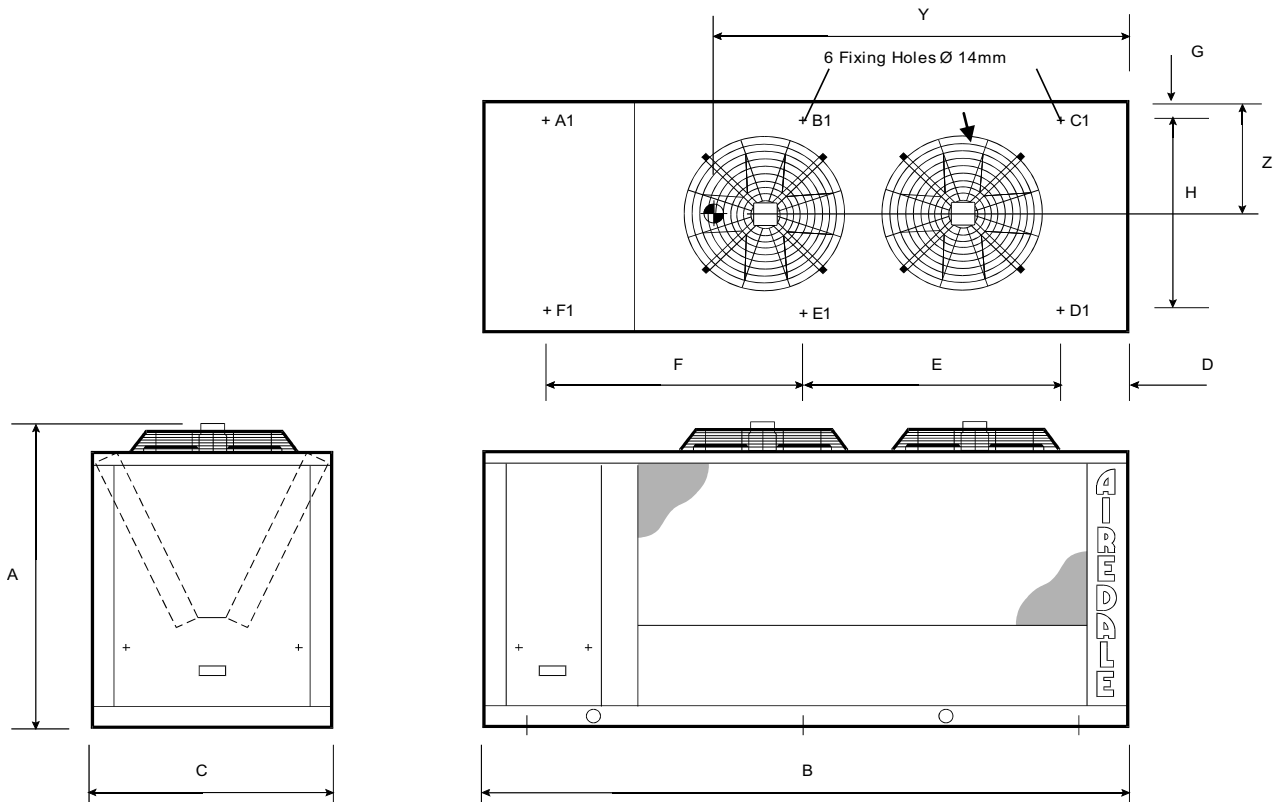

		A	B	C	D	E	F	G	H
CUS 15D	mm	1438	2300	1100	200	-	-	25	1050
CUS 20D	mm	1438	2900	1100	200	1250	1250	25	1050
CUS 25D	mm	1438	2900	1100	200	1250	1250	25	1050
CUS 30D	mm	1438	3000	1100	200	1300	1300	25	1050

	Point Loadings (kg)						Centre of Gravity (mm)	
	A1	B1	C1	D1	E1	F1	Y	Z
CUS 15D	146	-	101	101	-	156	1330	560
CUS 20D	130	120	56	56	121	140	1770	560
CUS 25D	130	122	57	57	123	141	1765	560
CUS 30D	174	140	78	77	138	179	1785	550

Notes:

- 1 Suction and liquid connections terminate underneath the condenser coil.
- 2 Allow 500mm around the unit for airflow and maintenance clearance.

Dimensions: CUS 40D - 60D

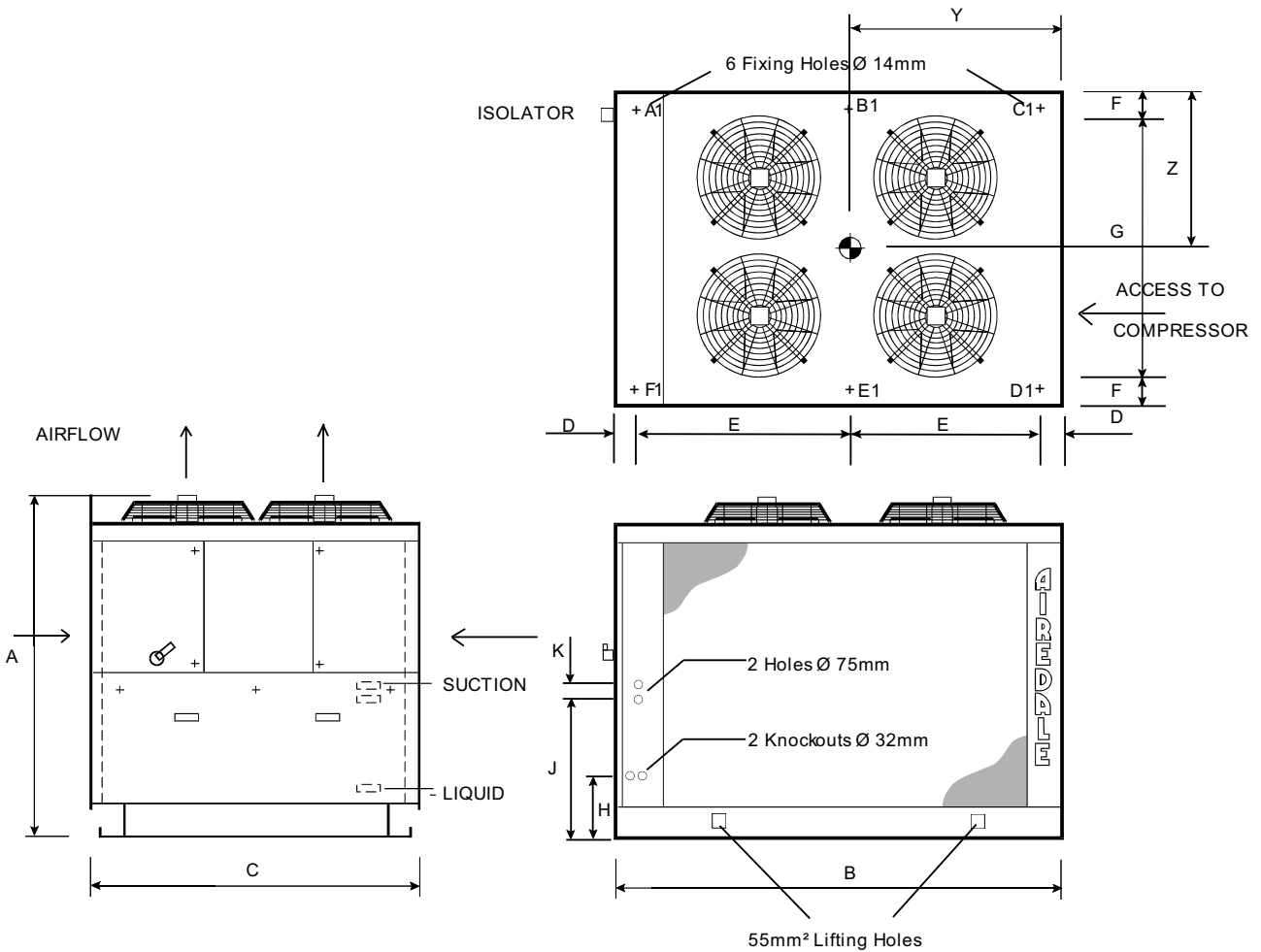

		A	B	C	D	E	F	G	H	J	K
CUS 40D	mm	1693	2440	1800	200	1020	75	1650	155	595	100
CUS 50D	mm	1693	2440	1800	200	1020	75	1650	155	595	100
CUS 60D	mm	1693	2440	1800	200	1020	75	1650	155	595	100

	Point Loadings (kg)						Centre of Gravity (mm)	
	A1	B1	C1	D1	E1	F1	Y	Z
CUS 40D	148	174	174	174	174	149	1169	896
CUS 50D	157	206	206	208	206	156	1136	900
CUS 60D	180	254	254	258	255	180	1116	900

Note: Allow 500mm around the unit for airflow and maintenance clearance.

Technical Data

CUS		15D	20D	25D	30D	40D	50D	60D
Nominal Capacity (1)	kW	41.8	50.2	71.1	80.7	104.0	131.4	161.4
Nominal Input (1)	kW	13.8	17.4	23.5	28.8	43.2	54.6	61.8
Capacity Steps	%	0-50-100	0-50-100	0-50-100	0-50-100	0-25-50-75-100	0-30-60-80-100	0-25-50-75-100
Construction		Galvanised Steel						
Material		Charcoal Grey (RAL 7022)						
Condenser		Air Cooled						
Type		Vertical						
Quantity		2	2	2	2	2	2	2
Face Area	m ²	2.47	3.46	3.46	3.46	5.75	5.75	5.75
Nominal Airflow	m ³ /s	4.00	4.80	6.80	6.80	9.60	13.60	13.00
Discharge		Vertical						
Fan		Axial						
Type		Axial						
Quantity		2	2	3	3	4	6	6
Diameter	mm	610	610	610	610	610	610	610
Maximum Speed	rpm	930	930	930	930	930	930	930
Compressor		Scroll						
Type		Tandem Scroll						
Quantity		2	2	2	2	4	4	4
Oil Charge Volume	L	3.2	3.8	4.0	6.6	3.8	3.8/6.6	6.6
Refrigeration		2						
Number of Circuits		R407C						
Refrigerant Type		Inert Gas						
Holding Charge								
Dimensions/Weights								
Height	mm	1438	1438	1438	1438	1693	1693	1693
Width	mm	2300	2900	2900	3000	2440	2440	2440
Depth	mm	1100	1100	1100	1100	1800	1800	1800
Machine Weight (nom)	kg	440	540	550	695	978	1119	1356
Operating Weight (nom)	kg	450	550	560	705	993	1139	1381
Connections								
Suction	in	1 1/8	1 1/8	1 1/8	1 3/8	1 5/8	2 1/8	2 1/8
Liquid	in	5/8	5/8	5/8	5/8	1 1/8	1 1/8	1 1/8
	}Sweat							

(1) Nominal Capacity based on 5°C evaporating and a 35°C ambient.

Electrical Data

CUS		15D	20D	25D	30D	40D	50D	60D
Unit Data								
Nominal Run Amps (1)	A	30.4	35.6	47.2	53.0	62.8	82.9	97.5
Maximum Start Amps	A	115.7	140.2	202.3	205.0	149.5	164.8	220.5
Control Circuit	V	24VAC						
Mains Supply	V	400/3/50						
Permanent Supply	V	230/1/50						
Rec Mains Fuse	A	50	50	80	80	100	100	125
Rec. Permanent Fuse(2)	A	4	4	4	4	4	4	4
Max Incoming) Mains	mm ²	25	25	35	35	50	50	95
Cable Size) Perm	mm ²	2.5	2.5	2.5	2.5	2.5	2.5	2.5
Compressor								
Motor Rating	kW	6.9	8.9	11.6	13.4	8.9	8.9/13.4	13.4
Nominal Run Amps (1)	A	12.7	15.2	19.8	22.5	15.2	15.2/22.5	22.5
Locked Rotor Amps	A	98	120.0	175.0	175.0	120.0	120.0/175.0	175.0
LRA Soft Start Option		49	60.0	88.0	88.0	-	-	-
Crankcase Heater Rating	W	50	50	50	75	50	50/75	75
Type of Start		Direct on Line						
Condenser Fan								
Motor Rating	kW	0.55	0.55	0.55	0.55	0.55	0.55	0.55
Full Load	A	2.50	2.50	2.50	2.50	2.50	2.50	2.50
Locked Rotor Amps	A	5.80	5.80	5.80	5.80	5.80	5.80	5.80

(1) Nominal Run Amps based on 5°C evaporating and a 35°C ambient.

pLAN Termination

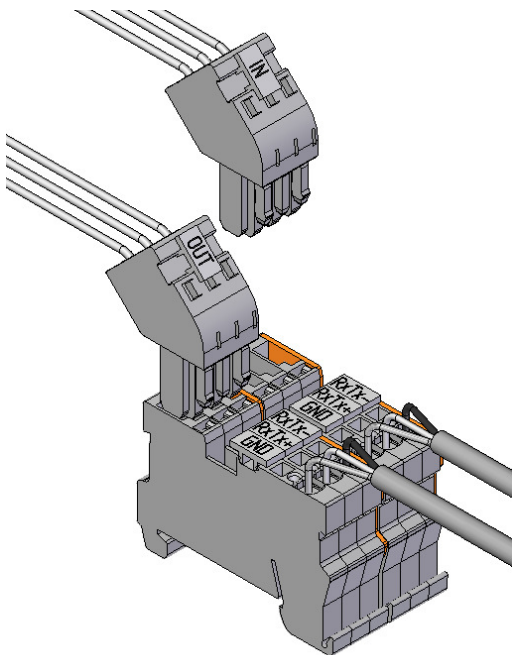

Noise Data

	Sound Measurement	dBa	Frequency (Hz)							
			63	125	250	500	1000	2000	4000	8000
CUS 15D	Power dB	84	88	80	81	81	81	74	66	57
	Pressure @ 1m	76	80	72	73	73	73	66	58	49
	Pressure @ 10m	56	60	52	53	53	53	46	38	29
CUS 20D	Power dB	85	88	80	82	82	82	75	68	59
	Pressure @ 1m	77	80	72	74	74	74	67	60	51
	Pressure @ 10m	57	60	52	54	54	54	47	40	31
CUS 25/30D	Power dB	86	88	81	83	83	82	78	72	64
	Pressure @ 1m	78	80	73	75	75	74	70	64	56
	Pressure @ 10m	58	60	53	55	55	54	50	44	36
CUS 40D	Power dB	101	95	93	89	89	95	95	93	91
	Pressure @ 1m	93	87	85	81	81	87	87	85	83
	Pressure @ 10m	73	67	65	61	61	67	67	65	63
CUS 50D	Power dB	103	97	95	92	92	98	98	95	90
	Pressure @ 1m	95	89	87	84	84	90	90	87	82
	Pressure @ 10m	75	69	67	64	64	70	70	67	62
CUS 60D	Power dB	105	98	95	92	94	99	100	97	90
	Pressure @ 1m	97	90	87	84	86	91	92	89	82
	Pressure @ 10m	77	70	67	64	66	71	72	69	62

Notes:

- 1 Sound Power Reference Power = 10^{-12} Watts.
- 2 Sound Pressure Reference Pressure = 2×10^{-5} N/m².
- 3 dBA is the overall noise level, measured on the A scale.
- 4 Sound Pressure data is only valid in free field conditions, where a reflective base, such as a roof is found.

Field Connections

CUS 15-30 UNITS	L1	○
	L2	○
	L3	○
	N	○
	E	○
	L4	○
	N1	○
	500	○
	502	○
	530	○
	535	○
	531	○
	532	○
526	○	
527	○	

- ➔ Mains Incoming
400/3/50
- ➔ L4-N1 Permanent Supply
230/1/50
- ➔ 0V
- ➔ 24VAC Customer's Control
- ➔ 502-530 Stage Two Cool - Customer's Control
- ➔ 502-535 Stage One Cool - Customer's Control
- ➔ 531-500 Liquid Line Solenoid - Circuit 2
- ➔ 532-500 Liquid Line Solenoid - Circuit 1
- ➔ 526-527 Common Volt Free Alarm N/O Contact

CUS 40-60 UNITS	L1	○
	L2	○
	L3	○
	N	○
	E	○
	L4	○
	N1	○
	500	○
	502	○
	506	○
	513	○
	522	○
	552	○
	523	○
	555	○
	507	○
	514	○
507	○	
514	○	
577	○	
578	○	
526	○	
527	○	

- ➔ Mains Incoming
400/3/50
- ➔ L4-N1 Permanent Supply
230/1/50
- ➔ 0V
- ➔ 24VAC - Customer's Control
- ➔ 502-506 Stage One Cool - Customer's Control
- ➔ 502-513 Stage Two Cool - Customer's Control
- ➔ 522-552 Stage Three Cool - Customer's Control
- ➔ 523-555 Stage Four Cool - Customer's Control
- ➔ 507-500 Liquid Line Solenoid 1 - Circuit 1
- ➔ 514-500 Liquid Line Solenoid 2 - Circuit 2
- ➔ 507-500 Liquid Line Solenoid 1 - Comp 1, Circuit 1
- ➔ 514-500 Liquid Line Solenoid 2 - Comp 1, Circuit 2
- ➔ 577-500 Liquid Line Solenoid 3 - Comp 2, Circuit 1
- ➔ 578-500 Liquid Line Solenoid 4 - Comp 2, Circuit 2
- ➔ 526-527 Common Volt Free Alarm N/O Contact

} Customer Supply



SYSTEMY HVAC Sp. z o.o.
ul. Rydygiera 8, 01-793 Warszawa
tel.: +48 22 101 74 00
fax: +48 22 101 74 01
e-mail: biuro@systemy-hvac.pl
www.systemy-hvac.pl